

Series 779 Venturi Check Valve

PRODUCT DESCRIPTION

The Victaulic Series 779 Venturi check valve provides a variety of functions unlike any other flow measuring device. The CAD-designed hydrodynamic inlet profile provides a natural venturi as part of the valve. The inlet is drilled, tapped and plugged, ready to receive the flow kit (optional in Canada).

The venturi-like taps provide much greater measurement accuracy than taps placed across the valve seat. Valve turbulence and interference across the valve seat need not be a consideration. Twin taps on both sides of the valve provide positioning of measurement outlets for

convenient meter connection and accurate flow measurement independent of the style of throttling valve or the position of the throttling element (ball, plug, disc, etc.).

Grooved end design allows direct connection to either Vic[®]-300 butterfly valves or Series 377 Vic-Plug[™] valves for triple service throttling and shutoff with non-slam check service and flow measurement capability. Vic-300 butterfly valves field connect with a single Style 07 Zero-Flex[®] coupling to form a single triple service unit. Series 377 Vic-Plug valve, an AWWA size component, connects

directly with a Style 307 Transition coupling.

Series 779 Venturi check valves are available in sizes from 4 - 14" (100 - 350 mm). (Note: For 2½ and 3" triple service combinations, the Series 716 Vic-Check[®] valve, without measurement ports, can be combined with a Vic-300 butterfly valve.) The valve features a single spring-loaded, non-slamming disc, totally encapsulated in EPDM or nitrile (specify coating) for superior corrosion resistance. The valves have a welded-in nickel seat and optionally available drain taps up and downstream.



Sizes 4 - 14"

Every valve is factory tested and rated to 300 psi (2065 kPa) working pressure. All sizes can be installed in horizontal or vertical position and provide leak-free sealing under conditions as low as five feet (1,5 m) of head pressure.

DIMENSIONS

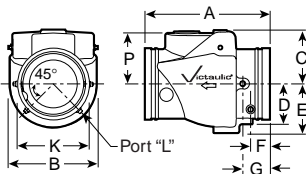

Typical 4"

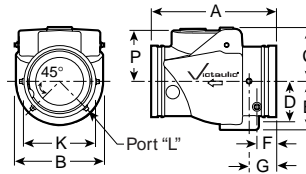

Typical 5 - 6"

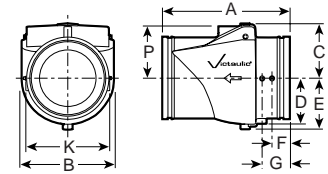

Typical 8 - 14"

Valve Size		Dimensions- Inches/millimeters									Aprx. Weight Each Lbs./kg
Nominal Diameter In./mm	Actual Outside Dia. In./mm	E - E A	B	C	D	E	F	G	K	P	
4† 100	4.500 114,3	9.63 245	5.88 149	3.88 99	2.75 70	3.50 89	1.50 38	2.38 60	4.50 114	3.50 89	16.0 7,3
5† 125	5.563 141,3	10.50 267	6.75 171	4.50 114	4.25 108	4.25 108	1.65 42	2.38 60	5.88 149	4.08 104	20.0 9,1
139,7 mm†	5.500 139,7	10.50 267	6.75 171	4.50 114	4.25 108	4.25 108	1.65 42	2.38 60	5.88 149	4.08 1,04	20.0 9,1
6† 150	6.625 168,3	11.50 292	8.00 203	5.00 127	4.50 114	4.50 114	1.58 40	2.68 68	6.68 170	4.75 121	28.0 12,7
165,1 mm†	6.500 165,1	11.50 292	8.00 203	5.00 127	4.50 114	4.50 114	1.58 40	2.68 68	6.68 170	4.75 121	28.0 12,7
8* 200	8.625 219,1	14.00 356	9.88 251	6.06 154	5.06 129	5.68 144	1.75 44	3.25 83	8.88 226	5.75 146	40.0 18,1
10* 250	10.750 273,0	17.00 432	12.00 305	7.12 181	6.00 152	6.68 170	1.82 46	3.94 100	10.94 278	6.94 176	100.0 45,4
12* 300	12.750 323,9	19.50 495	14.00 356	8.06 205	6.91 176	7.68 195	1.82 46	3.32 84	12.82 326	7.93 201	140.0 63,5
14 350	14.000 355,6	20.25 514	14.52 369	10.39 264	7.79 198	7.79 198	1.93 49	3.46 88	14.77 375	10.39 264	280.0 127,0

† Port "L" located 45° off centerline of valve body.

* Both ports on centerline of valve body.

VICTAULIC[®] IS AN ISO 9001 CERTIFIED COMPANY

Victaulic Company of America Phone: 1-800-PICK-VIC (1-800-742-5842) Fax: 610-250-8817 e-mail: pickvic@victaulic.com	Victaulic Company of Canada Phone: 416-675-5575 Fax: 416-675-5565 e-mail: viccanada@victaulic.com	Victaulic Europe Phone: 32-9-381-1500 Fax: 32-9-380-4438 e-mail: viceuro@victaulic.be	Victaulic America Latina Phone: 610-559-3300 Fax: 610-559-3608 e-mail: vical@victaulic.com	Victaulic Asia Pacific Phone: 65-235-3035 Fax: 65-235-0535 e-mail: vicap@victaulic.com
---	---	---	--	--

PERFORMANCE

C_v values for flow of water at +60°F (+16°C) with a fully open valve are shown in the table at right.

NOTE: Placement of check valves too close to sources of unstable flow will shorten the life of the valve and potentially may damage the system. To extend valve life, valves should be installed a reasonable distance downstream from pumps, elbows, expanders, reducers or other similar devices. Sound piping practices dictate a minimum of five (5) times the pipe diameter for general use. Distances between three (3) and five (5) diameters are allowable provided the flow velocity is less than eight (8) feet per second. Distances less than three (3) diameters are not recommended and will violate the Victaulic product warranty.

Formulas for C_v Values:

$$\Delta P = \frac{Q^2}{C_v^2}$$

$$Q = C_v \times \sqrt{\Delta P}$$

Where:

Q = Flow (GPM)

C_v = Flow Coefficient

ΔP = Pressure Drop (PSI)

Valve Size			Valve Size			Valve Size			Valve Size		
Nom. Dia. In./mm	Actual Out. Dia. In./mm	C_v (Full Open)	Nom. Dia. In./mm	Actual Out. Dia. In./mm	C_v (Full Open)	Nom. Dia. In./mm	Actual Out. Dia. In./mm	C_v (Full Open)	Nom. Dia. In./mm	Actual Out. Dia. In./mm	C_v (Full Open)
4 100	4.500 114,3	390	139,7 mm	5.500 139,7	700	165,1 mm	6.500 165,1	1000	10 250	10.750 273,0	3000
5 125	5.563 141,3	700	6 150	6.625 168,3	1000	8 200	8.625 219,1	1800	12 300	12.750 323,9	4200

Flow Characteristics

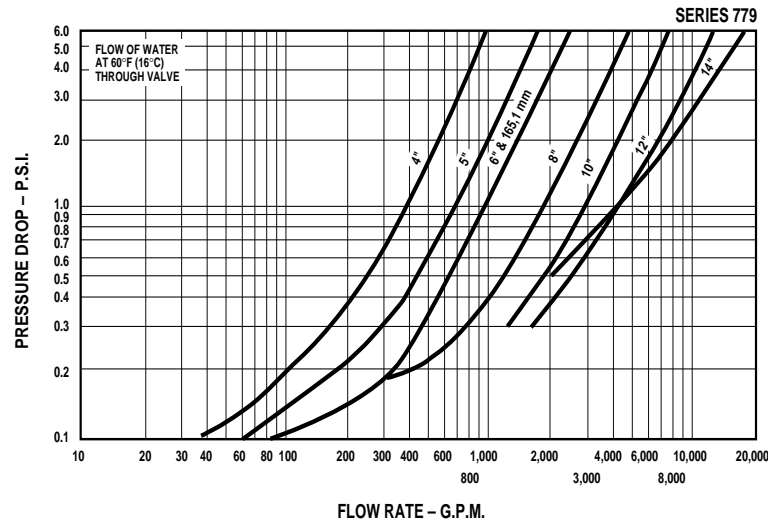

MATERIAL SPECIFICATIONS

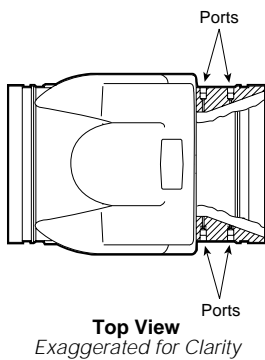

Body: Ductile iron conforming to ASTM A-395, grade 65-45-15, and ASTM A-536, grade 65-45-12, painted black enamel.
Seat: Integrally welded nickel alloy.

Disc Coating: (Specify Choice)

Grade "E" EPDM

EPDM (Green color code). Temperature range -30°F to +230°F (-34°C to +110°C). Recommended for hot water service within the specified temperature range plus a variety of dilute acids, oil-free air and many chemical services. UL classified in accordance with ANSI/NSF 61 for cold +86°F (+30°C) and hot +180°F (+82°C) potable water service. NOT RECOMMENDED FOR PETROLEUM SERVICES.

Grade "T" nitrile

Nitrile (Orange color code). Temperature range -20°F to +180°F (-29°C to +82°C). Recommended for petroleum

products, air with oil vapors, vegetable and mineral oils within the specified temperature range; except hot, dry air over +140°F (+60°C) and water over +150°F (+66°C). NOT RECOMMENDED FOR HOT WATER SERVICES.

Grade "O" fluoroelastomer

Fluoroelastomer (Blue color code). Temperature range +20°F to +300°F (-7°C to +149°C). Recommended for many oxidizing acids, petroleum oils, halogenated hydrocarbons, lubricants, hydraulic fluids, organic liquids and air with hydrocarbons to +300°F (+149°C).

*Services listed are General Service Recommendations only. It should be noted that there are services for which these disc lin-

ers are not recommended. Reference should always be made to the latest Victaulic Gasket Selection Guide for specific liner service recommendations and for a listing of services which are not recommended.

Discs: Ductile iron conforming to ASTM A-536, grade 65-45-12, and ASTM A-395, grade 65-45-15, fully encapsulated in Grade "E", "T", or "O" elastomer. (See disc coating)

Shaft: Type 316 stainless steel.

Spring: Type 302/304 stainless steel.

Shaft Plug: Carbon steel zinc plated to ASTM B-633.

Pipe Plug: Carbon steel zinc plated to ASTM B-633.

Kit: See page 4.

FLOW BALANCING DATA

4" Series 779

Flow Measuring Check Valve

ΔP PSI kPa	ΔP In. H ₂ O kPa	Velocity* Ft/Sec m/s	Flow GPM L/min.	ΔP PSI kPa	ΔP In. H ₂ O kPa	Velocity* Ft/Sec m/s	Flow GPM L/min.
0.16 1,1	4.4 1,1	3 0,91	119 450	1.65 11,4	45.8 11,4	10 3,05	397 1503
0.28 1,9	7.7 1,9	4 1,22	159 602	2.38 16,4	66.0 16,4	12 3,66	476 1802
0.61 4,2	16.9 4,2	6 1,83	238 901	3.28 22,6	90.9 22,6	14 4,27	556 2104
1.10 7,6	30.8 7,6	8 2,44	320 1211	4.28 29,5	118.7 29,5	16 4,88	635 2403

10" Series 779

Flow Measuring Check Valve

ΔP PSI kPa	ΔP In. H ₂ O kPa	Velocity* Ft/Sec m/s	Flow GPM L/min.	ΔP PSI kPa	ΔP In. H ₂ O kPa	Velocity* Ft/Sec m/s	Flow GPM L/min.
0.13 0,9	3.6 0,9	3 0,91	741 2805	1.36 9,4	37.7 9,4	10 3,05	2457 9300
0.23 1,6	6.4 1,6	4 1,22	983 3721	1.96 13,5	54.4 13,5	12 3,66	2948 11158
0.49 3,4	13.6 3,4	6 1,83	1474 5579	2.70 18,6	74.8 18,6	14 4,27	3440 13020
0.88 6,1	24.4 6,1	8 2,44	1966 7441	3.50 24,1	97.1 24,1	16 4,88	4000 15140

5" Series 779

Flow Measuring Check Valve

ΔP PSI kPa	ΔP In. H ₂ O kPa	Velocity* Ft/Sec m/s	Flow GPM L/min.	ΔP PSI kPa	ΔP In. H ₂ O kPa	Velocity* Ft/Sec m/s	Flow GPM L/min.
0.20 1,4	5.5 1,4	3 0,91	186 704	2.23 15,4	61.8 15,4	10 3,05	624 2362
0.35 2,4	9.7 2,4	4 1,22	249 942	3.13 21,6	86.8 21,6	12 3,66	744 2816
0.76 5,2	21.0 5,2	6 1,83	372 1408	4.25 29,3	117.8 29,3	14 4,27	868 3285
1.40 9,7	38.8 9,7	8 2,44	499 1889				

12" Series 779

Flow Measuring Check Valve

ΔP PSI kPa	ΔP In. H ₂ O kPa	Velocity* Ft/Sec m/s	Flow GPM L/min.	ΔP PSI kPa	ΔP In. H ₂ O kPa	Velocity* Ft/Sec m/s	Flow GPM L/min.
0.08 0,6	2.2 0,6	2 0,61	697 2638	1.28 8,8	35.5 8,8	8 2,44	2790 10560
0.18 1,2	5.0 1,2	3 0,91	1046 3959	2.04 14,1	56.6 14,1	10 3,05	3487 13198
0.33 2,3	9.1 2,3	4 1,22	1396 5284	2.80 19,3	77.6 19,3	12 3,66	4212 15942
0.71 4,9	19.7 4,9	6 1,83	2092 7918				

6" Series 779

Flow Measuring Check Valve

ΔP PSI kPa	ΔP In. H ₂ O kPa	Velocity* Ft/Sec m/s	Flow GPM L/min.	ΔP PSI kPa	ΔP In. H ₂ O kPa	Velocity* Ft/Sec m/s	Flow GPM L/min.
0.12 0,8	3.3 0,8	3 0,91	270 1022	1.39 9,6	38.5 9,6	10 3,05	901 3410
0.27 1,9	7.5 1,9	4 1,22	360 1363	2.0 13,8	55.5 13,8	12 3,66	1081 4092
0.51 3,5	14.1 3,5	6 1,83	540 2044	2.78 19,2	77.1 19,2	14 4,27	1261 4773
0.88 6,1	24.4 6,1	8 2,44	720 2725	3.6 24,8	99.8 24,8	16 4,88	1441 5454

14" Series 779

Flow Measuring Check Valve

ΔP PSI kPa	ΔP In. H ₂ O kPa	Velocity* Ft/Sec m/s	Flow GPM L/min.	ΔP PSI kPa	ΔP In. H ₂ O kPa	Velocity* Ft/Sec m/s	Flow GPM L/min.
0.06 0,4	1.6 0,4	2 0,61	860 3253	1.12 7,7	30.9 7,7	8 2,44	3438 13013
0.14 0,9	3.7 0,9	3 0,91	1289 4880	1.80 12,4	50.0 12,4	10 3,05	4298 16266
0.25 1,7	6.9 1,7	4 1,22	1719 6506	2.67 18,4	74.1 18,4	12 3,66	5157 19519
0.60 4,1	16.6 4,1	6 1,83	2579 9760				

8" Series 779

Flow Measuring Check Valve

ΔP PSI kPa	ΔP In. H ₂ O kPa	Velocity* Ft/Sec m/s	Flow GPM L/min.	ΔP PSI kPa	ΔP In. H ₂ O kPa	Velocity* Ft/Sec m/s	Flow GPM L/min.
0.10 0,7	2.7 0,7	3 0,91	471 1783	1.05 7,2	29.1 7,2	10 3,05	1559 5901
0.17 1,2	4.7 1,2	4 1,22	623 2358	1.55 10,7	43.0 10,7	12 3,66	1871 7082
0.38 2,6	10.5 2,6	6 1,83	936 3543	2.08 14,3	57.7 14,3	14 4,27	2182 8259
0.68 4,7	18.8 4,7	8 2,44	1247 4720	3.45 23,8	95.6 23,8	18 5,49	2800 10598

* Velocity based on flow rate through standard wall thickness pipe.

Venturi Check Valve

Series 779

1. Ductile iron body
2. Rubber encapsulated disc
3. Type 302/304 stainless spring
4. Type 316 stainless steel disc shaft
5. Elastomer shaft lock
6. Zinc plated shaft plug
7. Flow measuring kit*:
 - A. Extension nipples
 - B. Bronze access valves
 - C. Quick disconnect for meter connection (Per ISO 7241-1 Series B)
 - D. Easy-read flow chart and instructions (not shown)
8. Zinc plated, carbon steel drain plugs (optional)
9. Lifting ring (8 - 14" valves)
10. Name plate

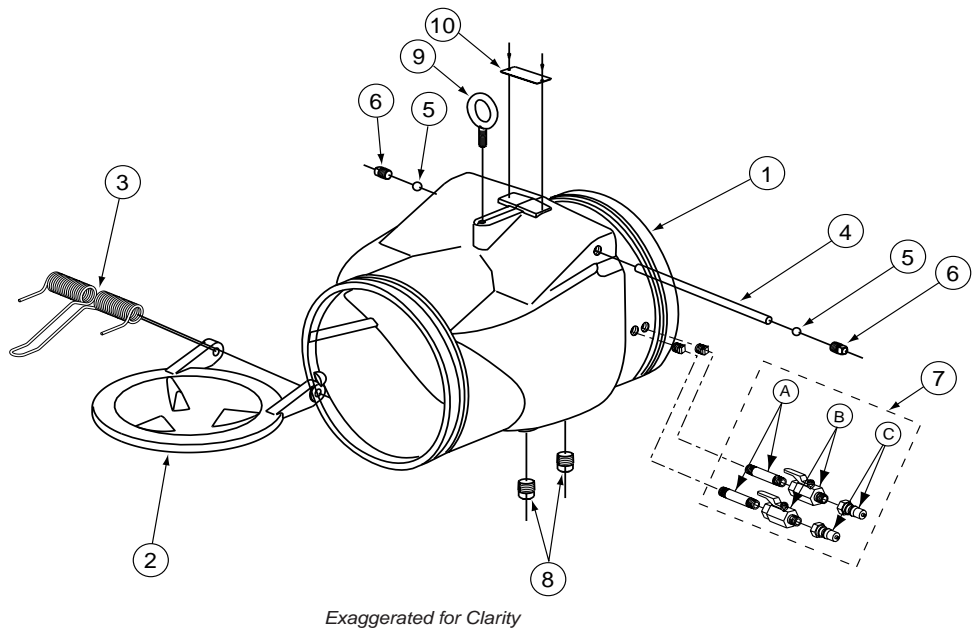

*Kit hardware is same for all sizes; charts for 4 and 5", 6 and 8", 10, 12 and 14".

Triple Service Valve Combinations

Grooved end design allows direct connection to either Vic®-300 butterfly valves or Series 377 Vic-Plug™ valves for triple service throttling and shutoff with non-slam check service and flow measurement capability. Vic-300 butterfly valves field connect with a single Style 07 Zero-Flex® coupling to form a single triple service unit. Series 377 Vic-Plug valve (an AWWA size component), connects directly with a Style 307 transition coupling. See Section 08.09.

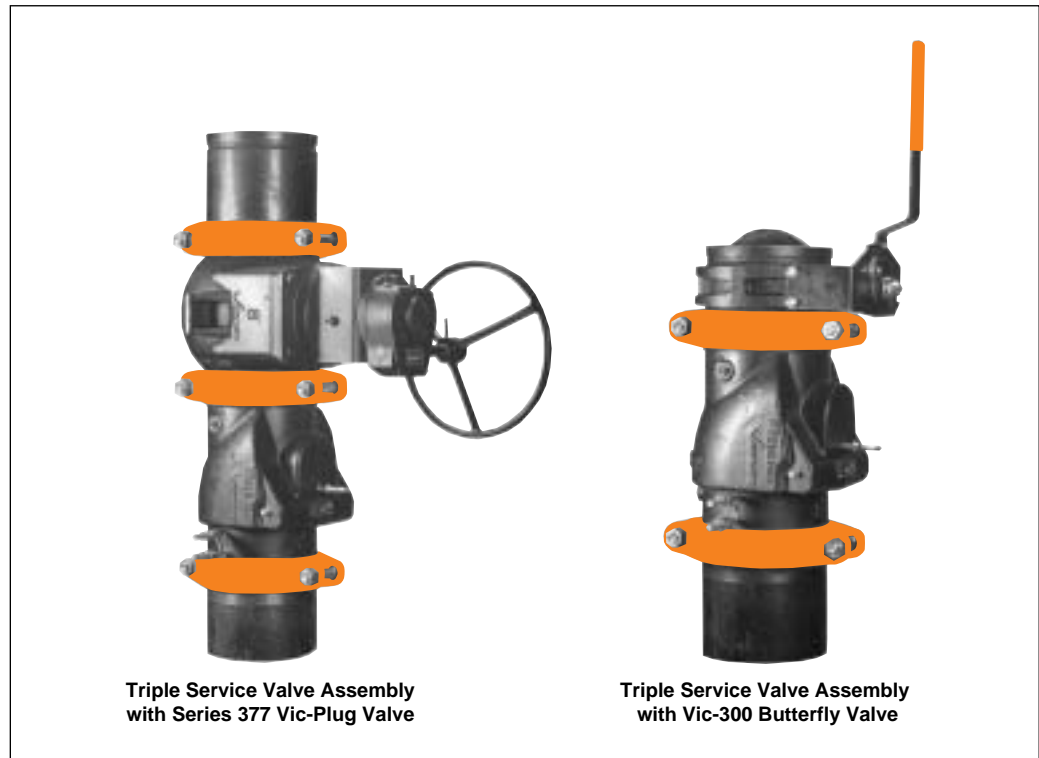

This product shall be manufactured by Victaulic Company. All products to be installed in accordance with current Victaulic installation/assembly instructions. Victaulic reserves the right to change product specifications, designs and standard equipment without notice and without incurring obligations.