

RED-WHITE

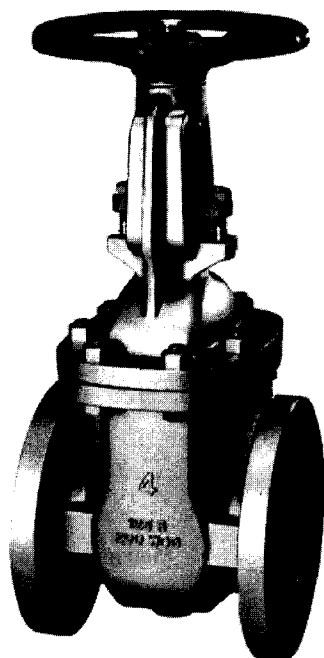

125-POUND CAST IRON GATE VALVES

MSS Specification Valves



Outside screw and yoke, bolted bonnet solid wedge disc, bronze trimmed, flanged end.

Pressure-Temperature Ratings

Service Temperature		Size 2" to 12"	
°F	°C	Psig	Bar
-20 to 150	-29 to 66	200	13.7
200	93	190	13.1
225	107	180	12.4
250	121	175	12.0
275	135	170	11.7
300	149	165	11.3
325	163	155	10.6
353(5)	178	150	10.3
375	191	145	10.0
406(6)	208	140	9.6
425	218	130	8.9
450	232	125	8.6
Hydrostatic test pressure	Shell	350	24.1
	Seat	220	15.2

Materials

No.	Name of parts	ASTM Specifications	
1	Body	Cast iron	A126 Class B
2	Bonnet	Cast iron	A126 Class B
3	Yoke	Cast iron	A126 Class B
4	Disc	Cast iron	A126 Class B
5	Handwheel	Ductile iron	A536 Grade 60-40-18
6	Body seat ring	Cast bronze	B62-C83600
7	Disc seat ring	Cast bronze	B62-C83600
8	Stem	Forged brass	B124-C37700
9	Gland	Ductile iron	A536-Grade 60-40-18
10	Yoke sleeve	Cast bronze	B62-C83600
11	Wheel nut	Steel*	A36
12	Washer	Brass plate	B36-C26000
13	Bonnet bolt	Steel*	A307 Grade B
14	Gland bolt	Steel*	A307 Grade B
15	Yoke bonnet bolt	Steel*	A307 Grade B
16	Bonnet bolt nut	Steel*	A563 Grade A
17	Gland bolt nut	Steel*	A563 Grade A
18	Yoke bonnet bolt nut	Steel*	A563 Grade A
19	Gland Packing	Non-asbestos packings	
20	Gasket	Non-asbestos sheet	
21	Sleeve nut	Cast iron	A126 Class B
22	Knock pin	Steel*	A36
23	Name plate	Aluminium plate	B209-1100

*Zinc plated

- Pressure-temperature ratings extracted from ANSI B16.1-1975 apply to cast iron flanged end valves designed for primary working pressure in class 125.
- Pressure ratings specified above are used for cast iron valves with metal-to-metal seating surfaces. Pressure temperature ratings for cast iron valves with non-metallic seat materials must be limited to reflect the physical characteristics of these materials at each temperature and may be lower, but in no case higher than values shown in the above table.
- The temperature shown to a corresponding pressure rating shall be the metal temperature of pressure containing parts. It shall be assumed that the metal temperature will be the temperature of the contained fluid. Application of a pressure rating at a metal temperature other than that of the contained fluid is strictly limited to the responsibility of the user.
- The pressure rating in service shall be restricted to the minimum temperature of -20°F (-29°C) as shown above.
- 353°F (Max.) to reflect the temperature of saturated steam at 125 psig.
- 406°F (Max.) to reflect the temperature of saturated steam at 250 psig.
- Valves conform to the requirements of MSS SP-70.

FIG. NO. 421AE

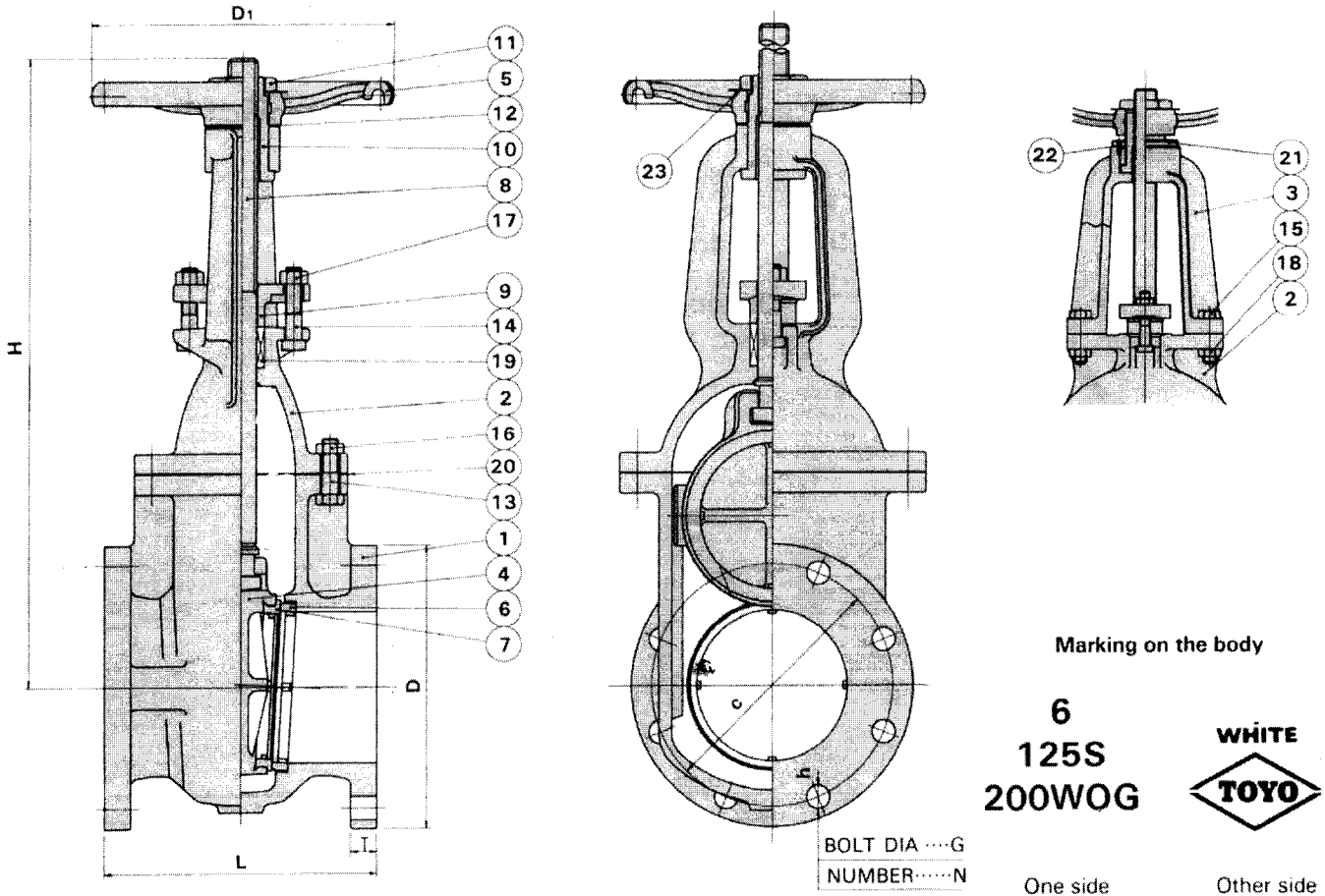

Marking on the body

6
125S
200WOG



BOLT DIAG
NUMBER.....N

One side Other side

Note:

- (1) Face-to-face dimensions conform to ANSI B 16.10.
- (2) End flange dimensions and drilling conform to ANSI B16.1. End flanges are fully flat faced and smooth finished in accordance with MSS SP-6.
- (3) Disc seat rings in all sizes are pressed into disc.
- (4) Body seat rings in all sizes are screwed into bodies.
- (5) Bodies are reinforced with a lateral rib in sizes 10" to 12".
- (6) Drain boss is provided in all sizes and by-pass bosses are provided in sizes 4" to 12"-inch valves at A, B, E & F positions in accordance with MSS SP-45.
- (7) Valves conforms to MSS SP-70.

Dimensions

Size	Mark	L	H	D ₁	Flanges					
					D	C	T	N	h	G
2	in.	7	14.1	7.1	6.00	4.75	0.62	4	0.75	0.62
	mm	178	357	180	152	121	15.9		19.0	15.9
2½	in.	7.5	16.2	7.1	7.00	5.50	0.69	4	0.75	0.62
	mm	190	412	180	178	140	17.5		19.0	15.9
3	in.	8	19.0	7.9	7.50	6.00	0.75	4	0.75	0.62
	mm	203	482	200	191	152	19.0		19.0	15.9
4	in.	9	22.4	9.8	9.00	7.50	0.94	8	0.75	0.62
	mm	229	569	250	229	191	23.8		19.0	15.9
5	in.	10	26.5	11.0	10.00	8.50	0.94	8	0.88	0.75
	mm	254	672	280	254	216	23.8		22.2	19.0
6	in.	10.5	30.8	11.8	11.00	9.50	1.00	8	0.88	0.75
	mm	267	783	300	279	241	25.4		22.2	19.0
8	in.	11.5	38.8	14.0	13.50	11.75	1.12	8	0.88	0.75
	mm	292	985	355	343	299	28.6		22.2	19.0
10	in.	13	47.1	15.7	16.00	14.25	1.19	12	1.00	0.88
	mm	330	1196	400	406	362	30.2		25.4	22.2
12	in.	14	54.8	17.7	19.00	17.00	1.25	12	1.00	0.88
	mm	356	1390	450	483	432	31.8		25.4	22.2

Weight

lb.	kg.
34	15.6
46	20.8
59	27.0
98	44.3
132	60.2
182	82.7
290	132.0
438	199.0
561	254.0

*Design and materials are subject to change without notice.