

RED-WHITE



125-POUND CAST IRON STRAINERS

"Y" pattern, stainless steel screen, bolted cover, flanged ends.



Working Pressure

Nominal pressure, non-shock		Hydrostatic test pressure
Steam	Water, oil & gas	Shell
Psig 125	200	350
Bar 8.6	13.8	24.1

Materials

No.	Name of Parts	ASTM Specifications	
1	Body	Cast iron	A126 Class B
2	Cover	Cast iron	A126 Class B
3	Screen	Stainless steel	A126 Type 304
4	Cover bolt	Steel*	A307 Grade B
5	Cover bolt nut	Steel*	A307 Grade B
6	Gasket	Non-asbestos joint sheet	
7	Drain plug	Malleable iron	A197

*Zinc plated

Note:

1. End flange dimensions and drillings conform to ASME B 16.1. End flanges are fully flat faced and smoothly finished in accordance with MSS SP-6.
2. JIS10K and BS/DIN PN16 flanged ends are available upon request.
3. The standard perforated screen is equivalent to 14-16 meshes.
4. 10-60 meshed screen is available upon request.

Marking on the body

6
125S
200WOG



One side

RED-WHITE



Other side

*Design and materials are subject to change without notice.

FIG. NO. 381AE

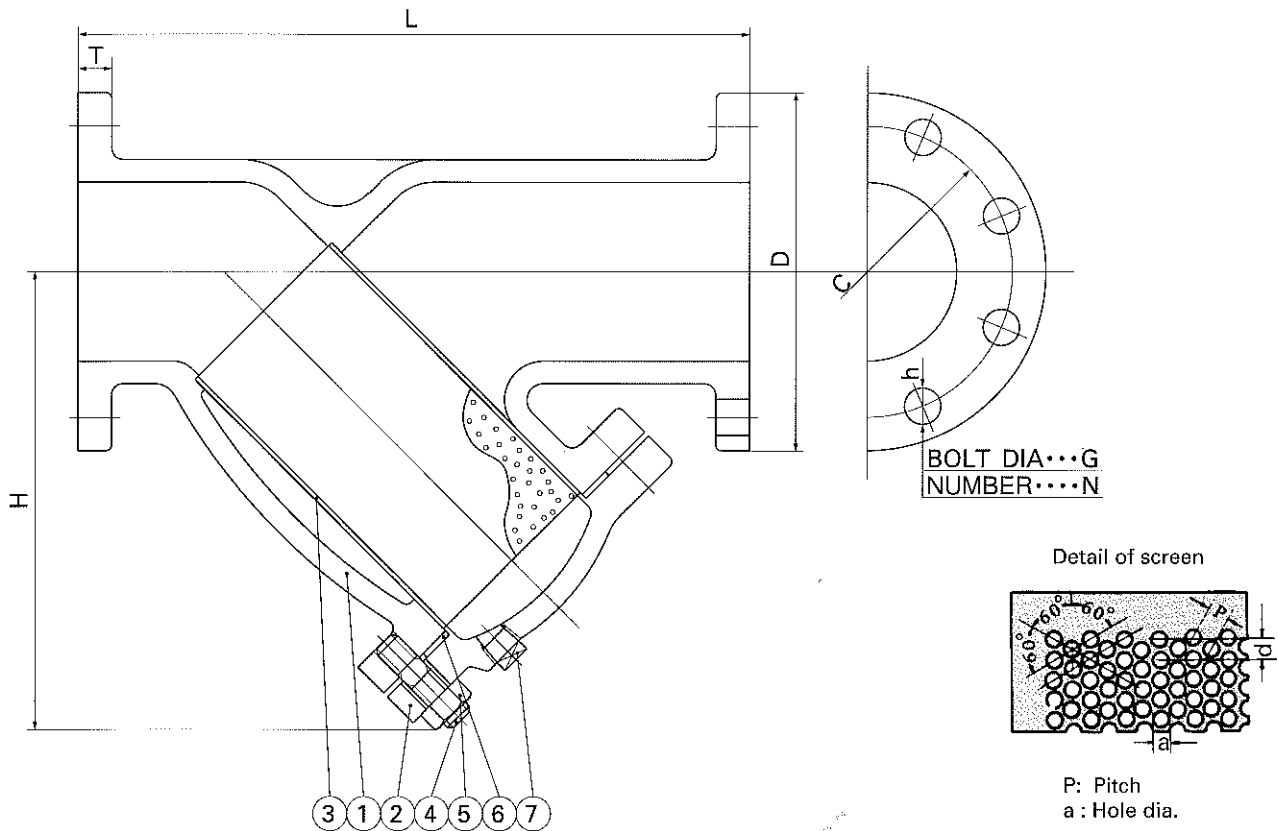

Dimensions

Size (in)	Mark (mm)	L	H	Flanges				Screen		Weight lb. kg.			
				D	C	N	h	G	T			a	P
2	in.	8.86	5.67	6.00	4.75	4	0.75	0.62	0.62	0.059	0.099	22	10
	mm	225	144	152	121		19.0	15.9	15.9	1.5	2.5		
2 1/2	in.	10.75	6.93	7.00	5.50	4	0.75	0.62	0.69	0.059	0.099	35	16
	mm	273	176	178	140		19.0	15.9	17.5	1.5	2.5		
3	in.	11.5	7.68	7.50	6.00	4	0.75	0.62	0.75	0.059	0.099	51	23
	mm	292	195	191	152		19.0	15.9	19.0	1.5	2.5		
4	in.	13.86	9.69	9.00	7.50	8	0.75	0.62	0.94	0.059	0.099	75	34
	mm	352	246	229	191		19.0	15.9	23.8	1.5	2.5		
5	in.	15.39	11.81	10.00	8.50	8	0.88	0.75	0.94	0.059	0.099	115	52
	mm	391	300	254	216		22.2	19.0	23.8	1.5	2.5		
6	in.	18.5	12.64	11.00	9.50	8	0.88	0.75	1.00	0.059	0.099	154	70
	mm	470	321	279	241		22.2	19.0	25.4	1.5	2.5		
8	in.	21.38	15.67	13.50	11.75	8	0.88	0.75	1.12	0.059	0.099	243	110
	mm	543	398	343	299		22.2	19.0	28.6	1.5	2.5		
10	in.	25.98	19.02	16.00	14.25	12	1.00	0.88	1.19	0.079	0.118	390	177
	mm	660	483	406	362		25.4	22.2	30.2	2.0	3.0		
12	in.	30	22.05	19.00	17.00	12	1.00	0.88	1.25	0.079	0.118	650	295
	mm	762	560	483	432		25.4	22.2	31.8	2.0	3.0		

Data of screen

Data	Size	2	2 1/2	3	4	5	6	8	10	12
Number of holes	in ²	119.4	119.4	119.4	119.4	119.4	119.4	119.4	82.8	82.8
	cm ²	18.5	18.5	18.5	18.5	18.5	18.5	18.5	12.8	12.8
Open area (%)		32.7	32.7	32.7	32.7	32.7	32.7	32.7	40.3	40.3
Total screen area	in ²	34.52	41.58	57.08	94.97	161.22	222.81	376.61	565.88	780.58
	cm ²	222.72	268.25	368.24	612.70	1040.12	1437.49	2429.74	3650.84	5036.00

Toyo Valve Co., Ltd.